

DHEUMIDIFYING DRYER (DMZ) Maintenance

(5) Honeycomb Rotor: Check rotation every six months

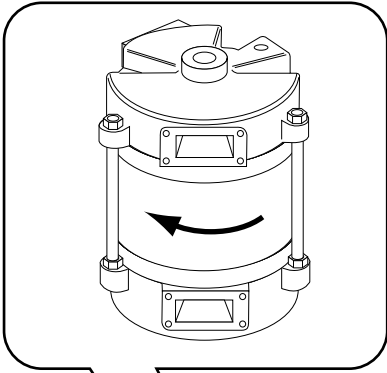

(2) Dust Tube: Clean Daily

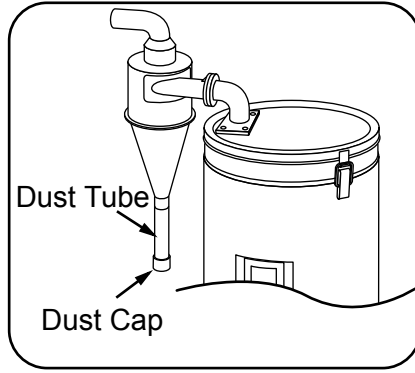

(3) Filter: Clean weekly

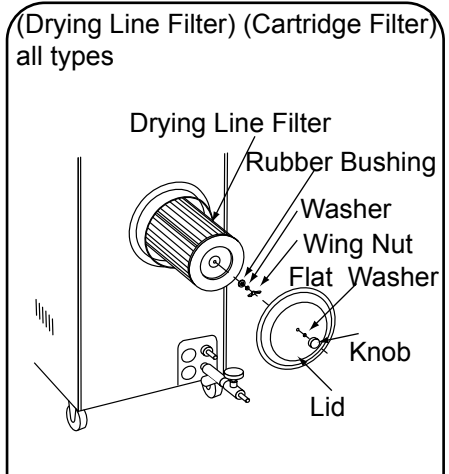

(4) Hose Disconnection/Air Leak: Check looseness weekly

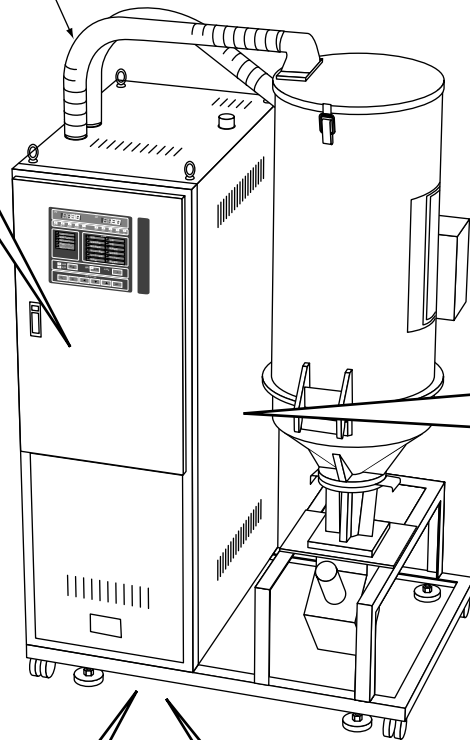

(Regenerate Filter)(Cartridge Filter) for DMZ-40

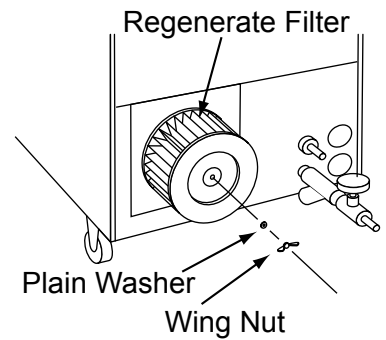

(7) Bolts/Nuts: Check every 6 months

(Regenerate Filter) (Cartridge Filter) for DMZ-80 and 120

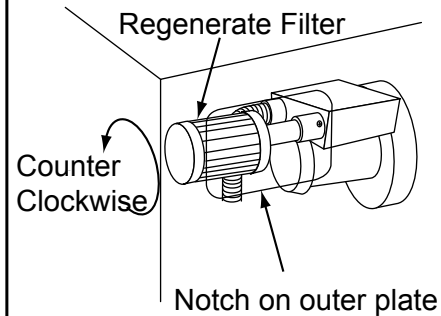

(6) Strainer: Clean every 6 months

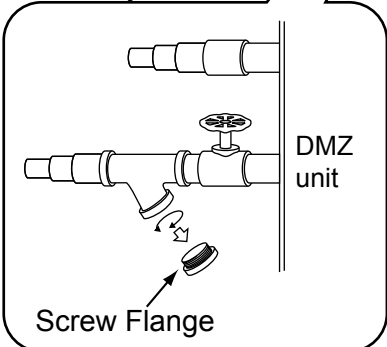

(1) Cooling Water: Check flow amount

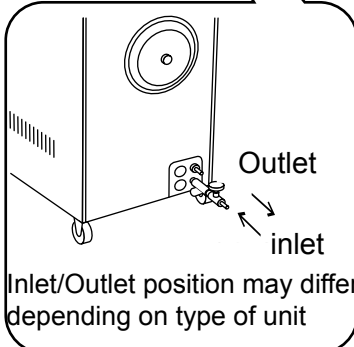

(Regenerate Filter) (Cartridge Filter) for DMZ-170 and 240

